

# Ultrasonic High-Efficiency Vertical 5-Axis Machining Center

## ULV800-5AXIS



### Technical Data

#### Controller

CNC Controller SIEMENS 840D sl (HEIDENHAIN / HNC Optional)

#### Spindle

Diameter	mm	Φ190
Max. Speed (Short-Duration)	rpm	20,000
Max. Speed (Long-Duration)	rpm	14,000
Spindle Taper	-	HSK-A63
Motor Power	kW	35
Motor Torque	Nm	85
Ultrasonic	-	Standard
Minimum Quantity Lubrication (MQL)	-	/
Ultrasonic + MQL	-	/

#### Tool Magazine

Tool Holding Capacity	No. of Tools	40
Max. Tool Diameter (Full)	mm	Φ75
Max. Tool Length	mm	300
Max. Tool Weight	kg	8
Tool Holder Spec.	-	HSK-A63
Type	-	Chain Type

#### Miscellaneous

Power Supply Voltage	-	Three-Phase AC, 380V/50Hz
Power Capacity	kVA	110
Air Pressure	MPa	0.5-0.7
Total Air Consumption	L/min	> 100
Total Weight (incl. Accessories)	kg	17,000
Machine Size (L×W×H)	mm	2,940× 4,310 ×3,310

#### Travel

X/Y/Z-Axis Travel	mm	800×1000×550
A/C-Axis Swivel Range	°	±100 /360

#### Worktable

Dimensions	mm	Φ800
Max. Load	kg	900
T-Slot (No.×Width)	pcs×mm	8-18H8
Max. Workpiece Size	mm	Φ800X500

#### Feed Rate

X/Y/Z-Axis Rapid Speed	m/min.	36/36/30
A/C-Axis Rapid Speed	rpm	30/70

#### Accuracy

X/Y/Z-Axis Positioning Accuracy	mm	0.008
X/Y/Z-Axis Repeatability	mm	0.005
A/C-Axis Positioning Accuracy	"	8
A/C-Axis Repeatability	"	5
Accuracy Grade	-	P

## Standard Configurations

Coolant System	Electrical Cabinet Heat Exchanger
Automatic Centralized Lubrication System	LED Work Light
Spindle Chiller	Three-Color Alarm Light
Contact Tool Setter	Door Safety Interlock
HEIDENHAIN Linear Encoders	5-Axis Simultaneous Machining System (with RTCP Function)
Electric Spindle	Anti-Collision System
Handwheel	Auto Chip Conveyor
Blow Gun	

## Optional Configurations

High Precision 3D Probe
Oil-Mist Collector
Laser Tool Setter
T64 Chain Type Tool Magazine
Spindle-Through Unit
Minimum Quantity Lubrication (MQL) System

## Floor Plans (Unit: mm)

### Front View

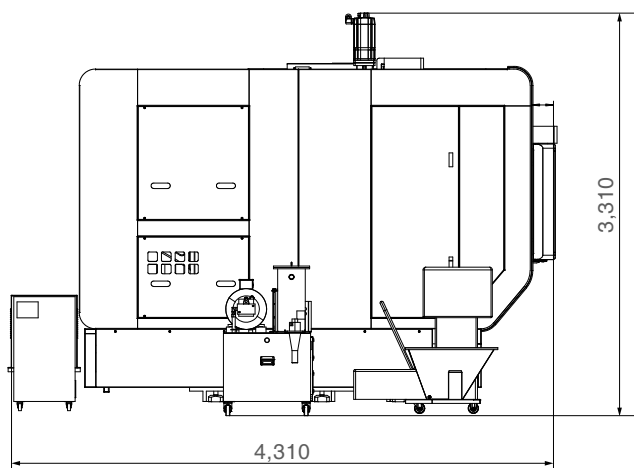

### Top View

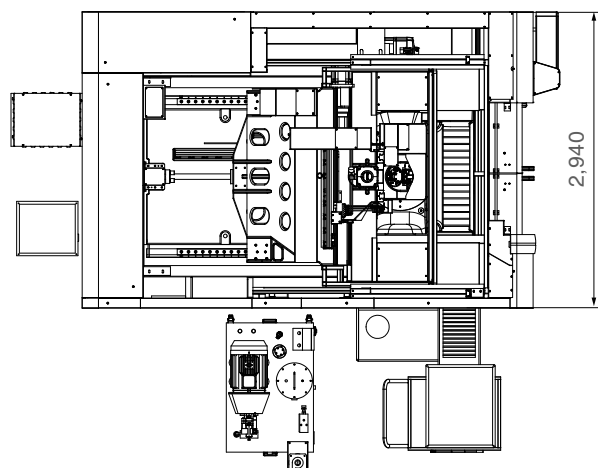

The information given is not binding. The actual product and mutual agreement shall prevail.

Contact: Esther HU +86-138 2607 9999

E-mail: [esther.hu@conprofotech.com](mailto:esther.hu@conprofotech.com)

Address: No.6 2nd Nanyun Road, Science City, Hi-tech Development Zone, Guangzhou, 510663, P.R.C

ULV800-5AXIS 20231122 VE.3