

Conprofe Vertical 5-Axis Simultaneous Machining Centers



ULV Series 

The information given is not binding. The actual product and mutual agreement shall prevail.

ULV Series 20231110 VE1.2

Conprofe Machine Tool Co., Ltd. // Wholly-Owned Subsidiary of Conprofe Technology Group Co., Ltd.

Contact: Esther HU +86-138 2607 9999 E-mail: esther.hu@conprofetech.com Web: www.conprofetech.cn
Address: No.6 2nd Nanyun Road, Science City, Hi-tech Development Zone, Guangzhou, 510663, P.R.C



Technical Parameters



Item	Unit	ULV200-5AXIS	ULV400-5AXIS
Travel			
X/Y/Z-Axis Travel	mm	280×580×280	420×800×380
A/C-Axis Swivel Range	°	±120/360	±120/360
Worktable			
Dimensions	mm	Φ 200	Φ 400
Max. Load	kg	30	200
T-Slot (No.×Width)	pcs×mm	4-14×H8	8-12×H8
Max. Workpiece Size	mm	Φ 200×190	Φ 455×260
Spindle			
Diameter	mm	Φ 100	Φ 155
Max. Speed (Short-Duration)	rpm	30,000	20,000
Max. Speed (Long-Duration)	rpm	25,000	16,000
Spindle Taper	-	HSK-E32	HSK-A63
Motor Power	kW	6	22
Motor Torque	Nm	2.7	29.2
Ultrasonic	-	Standard	Standard
Feed Rate			
X/Y/Z-Axis Rapid Speed	m/min	36/36/36	36/36/36
A/C-Axis Rapid Speed	rpm	100/200	100/150
Accuracy			
X/Y/Z-Axis Positioning Accuracy	mm	0.007	0.007
X/Y/Z-Axis Repeatability	mm	0.004	0.004
A/C-Axis Positioning Accuracy	"	8	8
A/C-Axis Repeatability	"	4	4
Tool Magazine			
Tool Holding Capacity	No. of Tools	40	40
Max. Tool Diameter (Full)	mm	Φ 50	Φ 70
Max. Tool Length	mm	200	200
Max. Tool Weight	kg	5	8
Type	-	Chain Type	Chain Type
Miscellaneous			
Power Supply Voltage	-	Three-Phase AC, 380V/50Hz	Three-Phase AC, 380V/50Hz
Power Capacity	kVA	16	30
Air Pressure	MPa	0.5-0.7	0.5-0.7
Total Air Consumption	L/min	>60	>100
Total Weight (incl. Accessories)	kg	4,000	7,000
Machine Size (L×W×H)	mm	1,600×2,700×2,080	2,000×3,310×2,420
Controller			
CNC Controller	-	SIEMENS 840D sl (Standard)	SIEMENS 840D sl (Standard)
		HEIDENHAIN / HNC (Optional)	HEIDENHAIN / HNC (Optional)

Technical Parameters



Item	Unit	ULV500-5AXIS	ULV650-5AXIS
Travel			
X/Y/Z-Axis Travel	mm	500×550×500	800×1,000×550
A/C-Axis Swivel Range	°	±120/360	±100/360
Worktable			
Dimensions	mm	Φ 500	Φ 650
Max. Load	kg	300	800
T-Slot (No.×Width)	pcs×mm	8-14×H8	8-18×H8
Max. Workpiece Size	mm	Φ 500×400	Φ 650×450
Spindle			
Diameter	mm	Φ 190	Φ 190
Max. Speed (Short-Duration)	rpm	20,000	20,000
Max. Speed (Long-Duration)	rpm	14,000	14,000
Spindle Taper	-	HSK-A63	HSK-A63
Motor Power	kW	35	35
Motor Torque	Nm	85	85
Ultrasonic	-	Standard	Standard
Feed Rate			
X/Y/Z-Axis Rapid Speed	m/min	36/36/30	36/36/30
A/C-Axis Rapid Speed	rpm	50/100	30/70
Accuracy			
X/Y/Z-Axis Positioning Accuracy	mm	0.007	0.008
X/Y/Z-Axis Repeatability	mm	0.004	0.005
A/C-Axis Positioning Accuracy	"	8	8
A/C-Axis Repeatability	"	5	5
Tool Magazine			
Tool Holding Capacity	No. of Tools	24	40
Max. Tool Diameter (Full)	mm	Φ 75	Φ 75
Max. Tool Length	mm	300	300
Max. Tool Weight	kg	8	8
Type	-	Umbrella Type	Chain Type
Miscellaneous			
Power Supply Voltage	-	Three-Phase AC, 380V/50Hz	Three-Phase AC, 380V/50Hz
Power Capacity	kVA	60	110
Air Pressure	MPa	0.5-0.7	0.5-0.7
Total Air Consumption	L/min	> 100	> 100
Total Weight (incl. Accessories)	kg	10,000	16,500
Machine Size (L×W×H)	mm	2,240×3,780×2,855	2,940×4,310×3,310
Controller			
CNC Controller	-	SIEMENS 840D sl (Standard) HEIDENHAIN / HNC (Optional)	SIEMENS 840D sl (Standard) HEIDENHAIN / HNC (Optional)

Technical Parameters



Item	Unit	ULV800-5AXIS	ULV1000-5AXIS	ULV1250-5AXIS
Travel				
X/Y/Z-Axis Travel	mm	800×1,000×550	1,250×1,250×1,000	1,250×1,250×1,000
A/C-Axis Swivel Range	°	±100/360	±100/360	±100/360
Worktable				
Dimensions	mm	Φ800	Φ1,000	Φ1,200
Max. Load	kg	900	1,000	1,200
T-Slot (No.xWidth)	pcs×mm	8-18×H8	8-18×H8	8-18×H8
Max. Workpiece Size	mm	Φ800×500	Φ1,000×500	Φ1,200×550
Spindle				
Diameter	mm	Φ190	Φ210	Φ210
Max. Speed (Short-Duration)	rpm	20,000	12,000	12,000
Max. Speed (Long-Duration)	rpm	14,000	10,000	10,000
Spindle Taper	-	HSK-A63	HSK-A100	HSK-A100
Motor Power	kW	35	26	26
Motor Torque	Nm	85	161	161
Ultrasonic	-	Standard	Standard	Standard
Feed Rate				
X/Y/Z-Axis Rapid Speed	m/min	36/36/30	30/30/30	30/30/30
A/C-Axis Rapid Speed	rpm	30/70	30/60	30/60
Accuracy				
X/Y/Z-Axis Positioning Accuracy	mm	0.008	0.008	0.008
X/Y/Z-Axis Repeatability	mm	0.005	0.005	0.005
A/C-Axis Positioning Accuracy	"	8	15	15
A/C-Axis Repeatability	"	5	8	8
Tool Magazine				
Tool Holding Capacity	No. of Tools	40	40	40
Max. Tool Diameter (Full)	mm	Φ75	Φ85	Φ85
Max. Tool Length	mm	300	320	320
Max. Tool Weight	kg	8	20	20
Type	-	Chain Type	Chain Type	Chain Type
Miscellaneous				
Power Supply Voltage	-	Three-Phase AC, 380V/50Hz	Three-Phase AC, 380V/50Hz	Three-Phase AC, 380V/50Hz
Power Capacity	kVA	110	110	110
Air Pressure	MPa	0.5-0.7	0.5-0.7	0.5-0.7
Total Air Consumption	L/min	>100	>100	>100
Total Weight (incl. Accessories)	kg	17,000	25,000	26,000
Machine Size (L×W×H)	mm	2,940×4,310×3,310	3,400×4,350×4,220	3,400×4,350×4,220
Controller				
CNC Controller	-	SIEMENS 840D sl (Standard) HEIDENHAIN / HNC (Optional)	SIEMENS 840D sl (Standard) HEIDENHAIN / HNC (Optional)	SIEMENS 840D sl (Standard) HEIDENHAIN / HNC (Optional)

Main Configurations

● Standard ○ Optional - No

	ULV200 -5AXIS	ULV400 -5AXIS	ULV500 -5AXIS	ULV650 -5AXIS	ULV800 -5AXIS	ULV1000 -5AXIS	ULV1250 -5AXIS
Coolant System	●	●	●	●	●	●	●
Centralized Automatic Lubrication System	●	●	●	●	●	●	●
Spindle Chiller	●	●	●	●	●	●	●
Contact Tool Setter	●	●	●	●	●	●	●
HEIDENHAIN Linear Encoders	●	●	●	●	●	●	●
Electrical Spindle	●	●	●	●	●	●	●
Handwheel	●	●	●	●	●	●	●
Blow Gun	●	●	●	●	●	●	●
Electrical Cabinet Heat Exchanger	●	●	●	●	●	●	●
LED Work Light	●	●	●	●	●	●	●
Three-Color Alarm Light	●	●	●	●	●	●	●
Door Safety Interlock	●	●	●	●	●	●	●
5-Axis Simultaneous Machining System (with RTCP Function)	●	●	●	●	●	●	●
Anti-Collision System	●	●	●	●	●	●	●
Auto Chip Conveyor	●	●	●	●	●	●	●
High Precision Probe	○	○	○	○	○	○	○
Oil-Mist Collector	○	○	○	○	○	○	○
Laser Tool Setter	○	○	○	○	○	○	○
Through-Spindle Cooling Unit	○	○	○	○	○	○	○
Minimum Quantity Lubrication (MQL) System	○	○	○	○	○	○	○
T40 Chain Type Tool Magazine	-	-	○	-	-	-	-
T64 Chain Type Tool Magazine	-	-	-	○	○	○	○

Floor Plans (Unit: mm)

ULV200-5AXIS

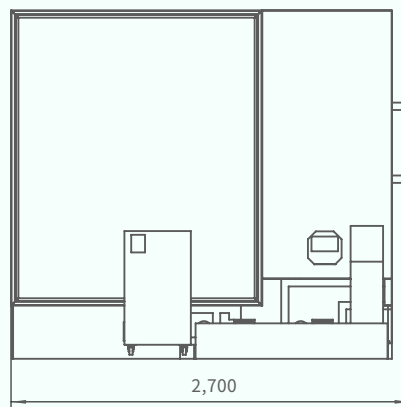
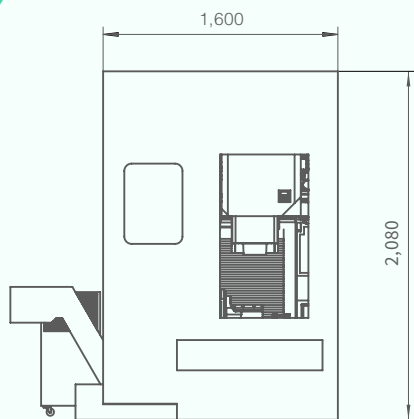

ULV400-5AXIS

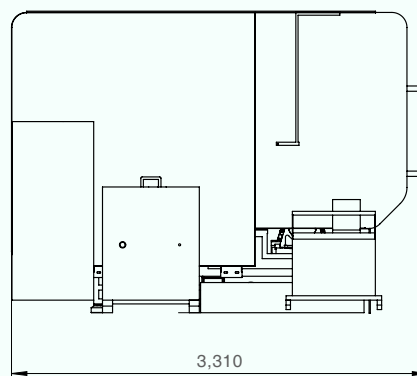
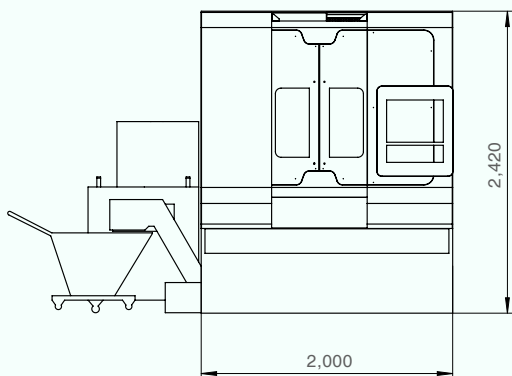

ULV500-5AXIS

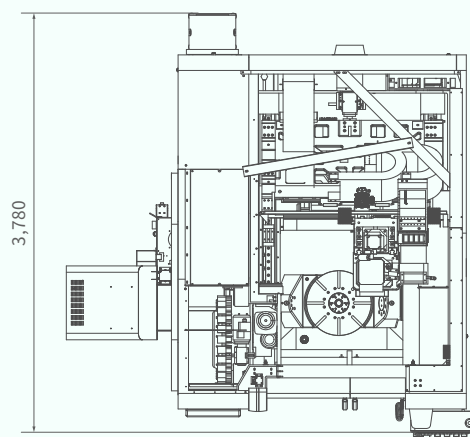
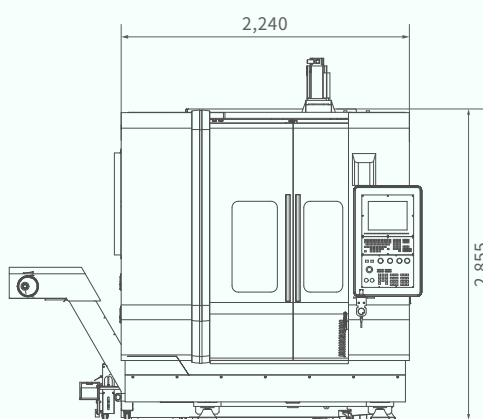

Floor Plans (Unit: mm)

ULV650-5AXIS

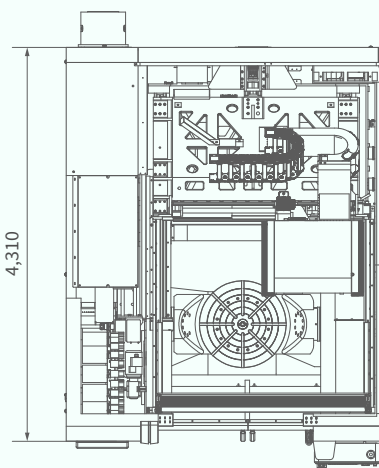
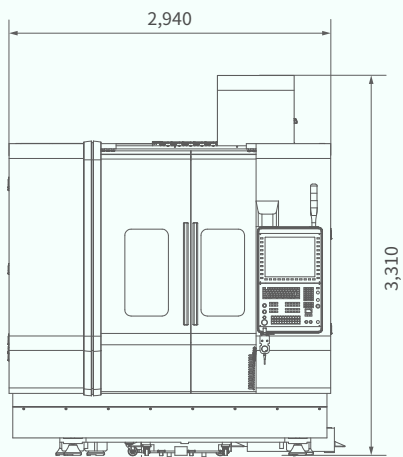

ULV1000-5AXIS

